

## DU146 M

### AUTOMATIC BYPASS AND DIFFERENTIAL PRESSURE VALVE FOR INSTALLATION IN DISTRICT HEATING SYSTEMS

#### PRODUCT DATA

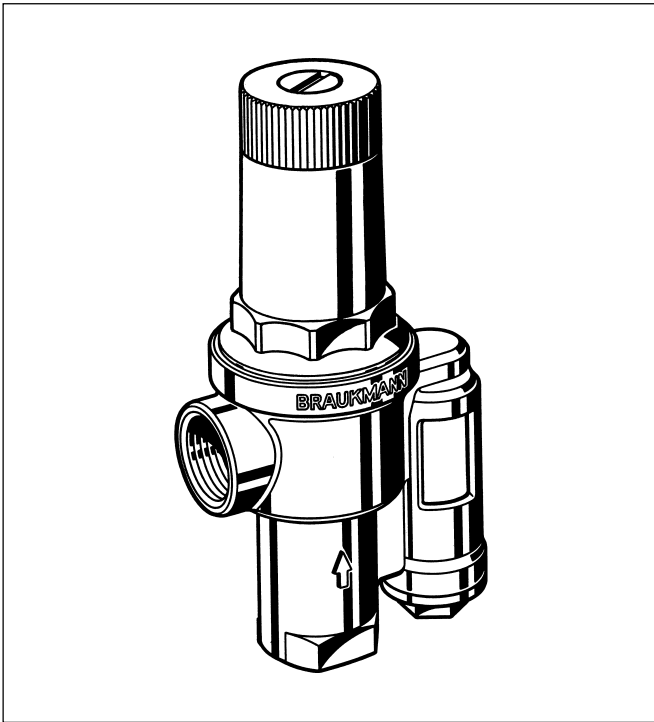

#### Design

The automatic bypass and differential pressure valve comprises:

- Body with internally threaded inlet and outlet
- Spring bonnet
- Adjustment facility
- Valve disc
- Spring

#### Materials

- Unpolished brass housing
- Untreated brass spring bonnet
- High-quality synthetic material adjuster knob
- Brass valve disc
- Stainless-steel spring
- EPDM seals

#### Application

The DU146 M automatic bypass and differential pressure valve is used to maintain constant differential pressure in a heating system. It reduces flow noise in a system, particularly as thermostatic radiator valves are closing. The boiler return temperature is raised and this reduces the corrosion caused by flue gas condensation. In addition, when radiator valves are closed it also maintains flow over the temperature sensor on the boiler to ensure proper operation of external temperature compensating controls. On gas fired water heaters it guarantees a minimum flow circulation when thermostats or radiator valves are closed.

#### Features

- Simple installation between the flow and return pipe-work
- Minimises flow noise
- No external controls required
- Differential pressure finely adjustable
- Problemlose Einregulierung durch eingebaute Differenzdruck-Istwertanzeige
- Hinders boiler corrosion
- Setting value is in meters water column
- Tried and tested

#### Range of Application

For pumped hot water heating systems

#### Specifications

<b>Medium</b>	Hot water
<b>Operating temperature</b>	max. 130°C (230°F)
<b>Operating pressure</b>	max. 16 bar (232 P.S.I.)
<b>Differential pressure</b>	Adjustable between 0,05...0,5 bar (0,7...7,3 P.S.I.) Set during manufacture at 0,2 bar (2,9 P.S.I.)
<b>Connection size</b>	3/4" and 1 1/4"

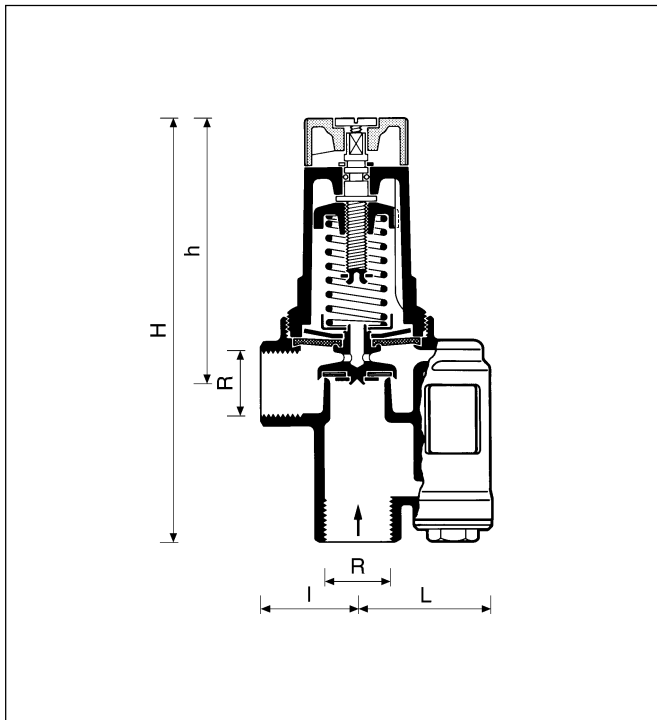

## Function

At equal pressure between the inlet and outlet side the valve is closed. The valve disc is pushed by a spring against the valve seat. If there is a pressure difference between the inlet and outlet sides, then a force is exerted on the valve disc and against the spring. If this force exceeds the force of the spring, then the valve begins to open in proportion to the rise in differential pressure and maintains a constant bypass flow as indicated on the flow diagram.

## Versions

A = Standard version  
Special version on request

Type R	Dimensions				Flow rate $\dot{V}$ m <sup>3</sup> /h	Ordering-No.
	L	I	H	h		
3/4"	36	50	160	100	3	DU146M-3/4A
1 1/4"	51	58	213	155	10	DU146M-1 1/4A

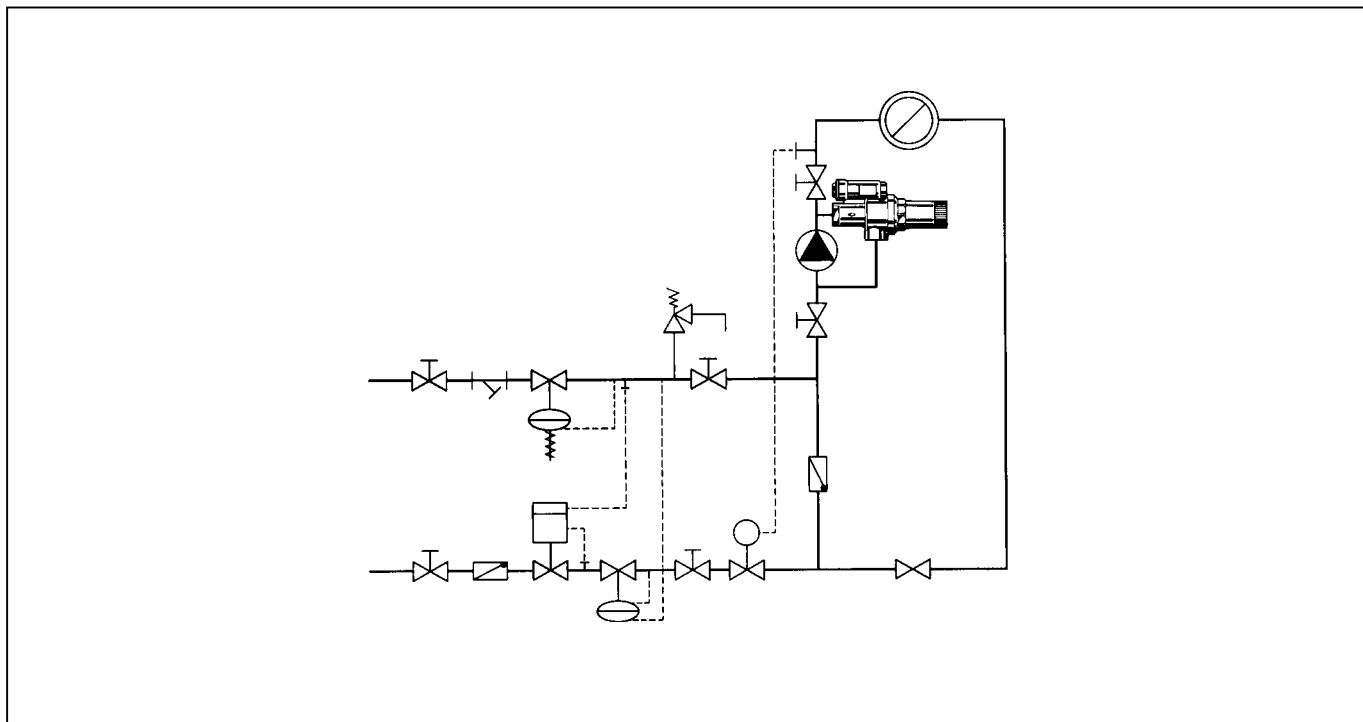

### Installation Guidelines

- Simple installation between flow and return
- For maintenance purposes it is recommended that shutoff valves be fitted on both sides of the bypass valve

### Typical Applications

Automatic bypass and differential pressure valves are installed in heating systems to maintain a constant differential pressure and to minimise water flow noise. DU146 M valves are specifically designed for district heating schemes, but they can also be used for heating installations with three and four way mixer valves, for example on gas fired hot water circulation systems

### Flow Diagram

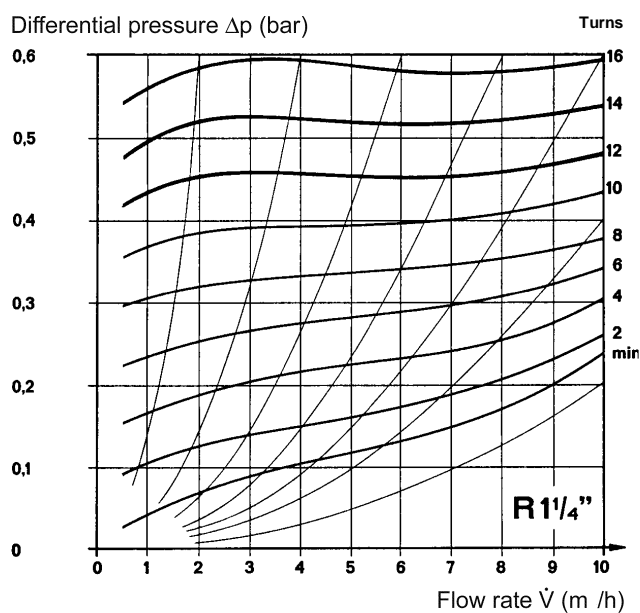
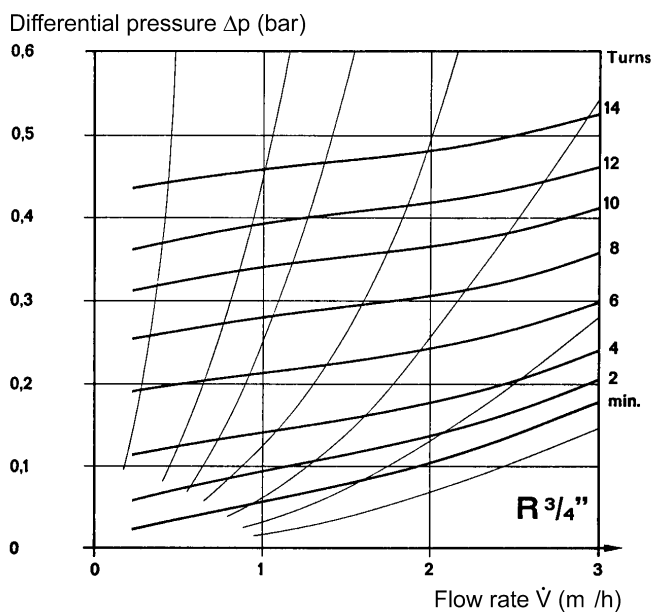

**Honeywell**

---

**Home and Building Control**

Honeywell AG  
Zu den Ruhrwiesen 3  
D-59755 Arnsberg-Neheim

Phone: (49) 2932 9880  
Fax: (49) 2932 988239  
mng@honeywell.com

<http://europe.hbc.honeywell.com>